

## Invited Review

# Regulation mechanisms for the heterodimeric transcription factor, PEBP2/CBF

S-C. Bae<sup>1</sup> and Y. Ito<sup>2</sup>

<sup>1</sup>Department of Biochemistry, School of Medicine, Chungbuk National University, Chungju, Korea and <sup>2</sup> Department of Cell Regulation Institute for Virus Research, Kyoto University Sakyo-ku, Kyoto, Japan

**Summary.** Members of the new PEBP2 (Polyomavirus Enhancer Binding Protein 2) family of heterodimeric transcriptional regulatory protein are composed of two subunits,  $\alpha$  and  $\beta$ . One of the genes encoding the  $\alpha$  subunit, *AML1/PEBP2 $\alpha$ B*, was identified at the breakpoints of various chromosome translocations, including t(8;21) and t(12;21) associated with acute myeloid leukemia and acute lymphoblastic leukemia, respectively. The gene encoding the  $\beta$  subunit (*PEBP2 $\beta$ /CBFB*) was also shown to be the target of the inversion of chromosome 16, another chromosomal anomaly associated with acute myeloid leukemia. Targeted disruption of either the *Aml1/Pebp2 $\alpha$ B* or *Pebp2 $\beta$ /Cbfb* gene resulted in strikingly similar phenotypes such as lack of definitive hematopoiesis of the fetal liver and accompanying hemorrhage of the central nervous system. These observations suggest that both  $\alpha$  and  $\beta$  subunits of PEBP2 are indispensable for its in vivo function. However, the heterodimerization of the  $\alpha$  and  $\beta$  subunit does not seem to occur readily suggesting that their capacity to associate might be an important rate limiting step in PEBP2 site-dependent transcription regulation. In this review, we concentrate on the possible regulatory mechanisms of PEBP2 activity in relation to leukemogenesis.

**Key words:** PEBP2, CBF, AML1, Hematopoiesis, Leukemia

### Introduction

Recent work has identified a new family of heterodimeric transcriptional regulatory proteins termed PEBP2/CBF (Polyomavirus Enhancer Binding Protein 2/Core Binding Factor), whose members play important roles in hematopoiesis and osteogenesis. PEBP2 is a sequence-specific DNA binding protein which recognizes a specific DNA sequence originally identified

in the polyomavirus enhancer (Bae et al., 1993; Ogawa et al., 1993a,b). The core binding factor (CBF) was independently identified as a factor that binds to the Moloney MLV enhancer and was found to be identical to PEBP2 (Wang et al., 1993). Each member of the PEBP2/CBF family of transcription factors is composed of two subunits,  $\alpha$  and  $\beta$ . The  $\alpha$  subunit is encoded by three distinct genes, while only one gene is known to encode for the  $\beta$  protein in mammals. The  $\beta$  subunit does not bind to DNA by itself, but binds to the  $\alpha$  protein and increases the binding affinity of the  $\alpha$  protein for DNA. Three closely related mammalian PEBP2 $\alpha$  genes, termed *PEBP2 $\alpha$ A* ( $\alpha$ A), *PEBP2 $\alpha$ B* ( $\alpha$ B) and *PEBP2 $\alpha$ C* ( $\alpha$ C) have been reported previously (Bae et al., 1993, 1995; Ogawa et al., 1993b; Levanon et al., 1994). The gene termed *AML1* was originally identified at the breakpoint of the chromosome translocation, t(8;21) associated with acute myeloid leukemia (Miyoshi et al., 1991) (see below). *AML1* was found to correspond to *PEBP2 $\alpha$ B*. The relationship between the present nomenclature and the nomenclature proposed by other investigators is shown in Table 1. Several alternatively spliced forms are transcribed from each gene. The products of the major transcripts from these three genes are referred to as PEBP2 $\alpha$ A1, PEBP2 $\alpha$ B1 and PEBP2 $\alpha$ C1, respectively.

Each of the three PEBP2 $\alpha$  gene products are highly homologous to the Drosophila runt (Kania et al., 1990) and lozenge (Daga et al., 1996) within a 128 amino acid region which harbors two different activities: (1) the ability to bind DNA; and (2) the ability to interact with the  $\beta$  subunit. The evolutionarily conserved 128 amino acid region has been called the Runt domain (Kagoshima et al., 1993). Fig. 1 shows a diagrammatic representation of the mammalian and fruit fly Runt domain containing proteins. The Runt domain shows no obvious homology to other DNA binding, or protein dimerization motifs, a characteristic that distinguishes it from other transcriptional regulatory proteins. In contrast to other heterodimeric transcription regulators like bHLH and bZIP, which bind to DNA only as dimers, the Runt domain containing proteins binds to DNA in the absence of a partner protein, albeit less strongly. Also,

Offprint requests to: S-C. Bae Ph.D., Department of Biochemistry, School of Medicine, Chungbuk National University, Chungju, 360-763, Korea. e-mail: scbae@med.chungbuk.ac.kr

## Heterodimeric transcription factor, PEBP2/CBF

**Table 1.** Comparison of nomenclatures of PEBP2/CBF proteins proposed by various investigators. There are three mammalian genes encoding distinct  $\alpha$  subunits of PEBP2: *PEBP2 $\alpha$ A*, *PEBP2 $\alpha$ B* and *PEBP2 $\alpha$ C*. There is only one mammalian gene encoding  $\beta$  subunit, *PEBP2 $\beta$* . Corresponding names proposed by other investigators are listed on the right of each name.

$\alpha$ SUBUNIT			$\beta$ SUBUNIT	
PEBP2 $\alpha$ A <sup>1</sup>	CBF $\alpha$ 1 <sup>4</sup>	AML3 <sup>5</sup>	PEBP2 $\beta$ <sup>7</sup>	CBF $\beta$ <sup>8</sup>
PEBP2 $\alpha$ B <sup>2</sup>	CBF $\alpha$ 2 <sup>4</sup>	AML1 <sup>6</sup>		
PEBP2 $\alpha$ C <sup>3</sup>	CBF3 $\alpha$ <sup>4</sup>	AML2 <sup>5</sup>		

1: Ogawa et al., 1993b; 2: Bae et al., 1993; 3: Bae et al., 1995; 4: Speck and Stacy, 1995; 5: Levanon et al., 1994; 6: Miyoshi et al., 1991; 7: Ogawa et al., 1993a; 8: Wang et al., 1993.

heterodimerization of the  $\beta$  subunit with the  $\alpha$  subunit stimulates the DNA binding activity of the complex without altering specificity for the recognition sequence. The consensus sequence recognized by the  $\alpha$  subunit was determined as 5'-Pu/TACCPuCPu-3' or 5'-PyGPyGGTPy/A-3' (Melnikova et al., 1993; Meyers et al., 1993; Ogawa et al., 1993b; Bae et al., 1994; Wotton et al., 1994).

At least three alternatively-spliced isoforms,  $\beta$ 1,  $\beta$ 2 and  $\beta$ 3, are generated from the *PEBP2 $\beta$*  gene. Their structures, together with the organization of the *PEBP2 $\beta$*  gene are shown in Fig 2.  $\beta$ 1 and  $\beta$ 2 are two major isoforms that heterodimerize without any noticeable preference with  $\alpha$ A,  $\alpha$ B and  $\alpha$ C. They share a common N-terminal 133 amino acid sequence encoded by exon 1-4 (Fig. 2) which is responsible for the heterodimerization

property of the  $\beta$  protein with the Runt domain. In contrast,  $\beta$ 3 only weakly enhances the DNA-binding of the  $\alpha$  subunit, and a super-shift band was not readily apparent in the electrophoretic mobility shift assay, even though the protein contained a 133-amino acid region which is sufficient for heterodimerization with the  $\alpha$  subunit. The only structural difference between  $\beta$ 1 and  $\beta$ 3 is the absence of exon 5 encoded region from  $\beta$ 3. Therefore, it was suggested that  $\beta$ 1 and  $\beta$ 2 are functional, but that  $\beta$ 3 is not (Ogawa et al., 1993b). However, a recent functional analysis of PEBP2 using a luciferase assay revealed that  $\beta$ 3 is also as functionally active as  $\beta$ 1 and  $\beta$ 2 under certain assay conditions (Kanno et al., 1998b). Further analysis will be necessary to clarify the properties of  $\beta$ 3.

## Drosophila homologs of mammalian PEBP2

PEBP2 $\alpha$  proteins share a 128-amino acid region with the *Drosophila melanogaster* Runt protein. *Runt* was initially characterized because of its role as one of the pair-rule genes during segmentation (Gergen and Wieschaus, 1985, 1986) and was subsequently found to have roles in two other developmental processes of the fly - sex determination and neurogenesis (Duffy and Gergen, 1991; Duffy et al., 1991). In each pathway, runt regulates the expression of other genes. Recently, another Runt domain containing gene, *lozenge*, was found in *Drosophila*. *Lozenge* is involved in pre-patterning photoreceptor precursors in the developing fruit fly eye (Daga et al., 1996). *Lozenge* does not function as a cell-specific transcription factor, rather it

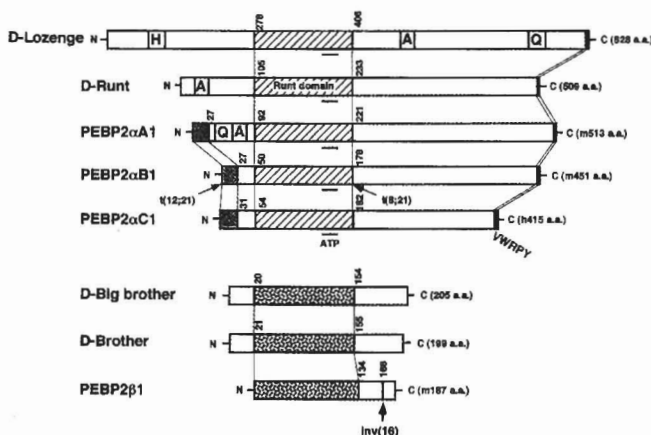

**Fig. 1.** Diagrammatic representation of the five Runt domains containing  $\alpha$  proteins and three  $\beta$  proteins. D-runt (Kania et al., 1990), D-Lozenge (Daga et al., 1996) D-Brother and D-Bigbrother (Golling et al., 1996) are *Drosophila* proteins. The remainder are mammalian. The upper five proteins share the Runt domain internally and the VWRPY motif at the C-terminal end. Speckled region in three  $\beta$  proteins share high homology between *Drosophila* and mammalian proteins. ATP: a sequence homologous to the consensus ATP/GTP binding site. A: Alanine stretch. H: Histidine stretch. Q: Glutamine stretch. Positions of introns in which the t(8;21), t(12;21) and inv(16) breakpoint are clustered are shown.

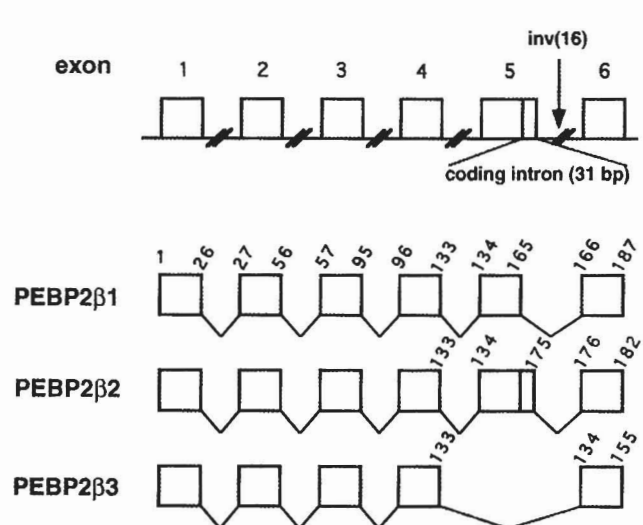

**Fig. 2.** PEBP2/CBF $\beta$  isoforms generated by alternative splicing. The genomic structure of the *PEBP2 $\beta$*  gene is shown on the top (Ogawa et al., 1993a). The genomic structure of human and mouse *PEBP2 $\beta$*  genes is virtually identical. The breakpoint cluster region of inv(16) is located between exon 5 and 6 (Liu et al., 1993). Protein isoforms generated by alternative splicing are shown below. Numbers at the top represent the amino acid numbers.

prepatterns the eye disc by positioning cell specific factors in their appropriate locations (Flores et al., 1998). Amino acid sequence homology between the Runt domain of fruit fly runt and that of lozenge is 69%, whereas the homology between the three mammalian Runt domains is about 92%, suggesting that the three mammalian genes evolved from a common ancestor. It is not clear which of the fruit fly genes is the ancestor of the mammalian runt gene family since both runt and lozenge are about 70% homologous to these three mammalian proteins.

In light of the high degree of homology, it is not surprising that fruit fly runt binds to the consensus DNA recognition sequence of mammalian PEBP2 and forms a heterodimer with the mammalian  $\beta$  subunit (Kagoshima et al., 1993). This cross-species interaction not only indicates an evolutionarily conserved role for the Runt domain but would also indicate that the fruit fly possesses a homolog of the mammalian  $\beta$  subunit. This speculation led to the isolation of fruit fly homologs of  $\beta$  gene, *Brother* (*Bro*) and *Bigbrother* (*Bgb*). They are also referred to as *rpb1* and *rpb2*, respectively (Fujioka et al., 1996; Golling et al., 1996). Alignment of the sequence of these proteins has allowed the identification of a large block of homology between mammalian and fruit fly  $\beta$  proteins. The homologous region begins with the initiating methionine and extends up to amino acid residue 137 of the mammalian  $\beta$  protein. This conserved segment almost coincides with the boundaries of the region determined to be responsible for dimerization with the Runt domain. Within the large conserved block, three proteins are identical at 70 positions (51% identity). There is a 5-amino acid insertion in the mouse  $\beta$  sequence which splits the conserved block approximately in half. Much of the variation within the conserved block is adjacent to this insertion, suggesting that the conserved block actually comprises two separate subregions or domains.

### Biological activity of PEBP2

Important clues about the biological activity of PEBP2 were obtained when independent results from a number of laboratories indicated that *PEBP2 $\alpha$*  and  $\beta$  genes were involved in human disease. One of the *PEBP2 $\alpha$*  genes, *AML1/PEBP2 $\alpha$ B*, is involved at the breakpoint of the chromosome translocations t(8;21), associated with the French-American-British (FAB) M2 subtype of acute myelogenous leukemia (AML), and t(12;21) associated with childhood acute lymphoblastic leukemia (ALL). The t(8;21) and t(12;21) translocations produce the chimeric proteins, AML1-ETO(MTG8) and TEL-AML1, respectively (Erickson et al., 1992; Miyoshi et al., 1993; Golub et al., 1995; Romana et al., 1995). The  $\beta$  subunit gene is also rearranged in inv(16) of FAB M4Eo subtype of AML, producing chimeric protein PEBP2/CBF $\beta$ -SMMHC (Liu et al., 1993). This protein has been shown to contribute to the genesis of myelodysplasia in a transgenic mice model (Kogan et

al., 1998). The involvement of PEBP2 genes in various types of chromosome translocations has been reviewed (Liu et al., 1995; Nucifora and Rowley, 1995; Speck and Stacy, 1995; Ito and Bae, 1997). Recently, both  $\alpha$  and  $\beta$  subunits were shown to be essential for hematopoiesis in mice. Targeted disruption of either the *Pebp2 $\alpha$ B/Aml1* or *Pebp2 $\beta$ /Cbfb* gene resulted in strikingly similar phenotypes. Embryos with a homozygous mutation in *Pebp2 $\alpha$ B/Aml1* lacked definitive hematopoiesis of the fetal liver and died around embryonic day 12.5 with accompanying hemorrhage of the central nervous system (Okuda et al., 1996; Wang et al., 1996a). The homozygous *Pebp2 $\beta$*  null knockout mutation in mice also showed similar impairment of definitive hematopoiesis. Severe hemorrhage in cerebral ventricles was also seen in E12.5 *Pebp2 $\beta$*  (-/-) embryos (Fig. 3) (Niki et al., 1997). These almost indistinguishable knockout phenotypes, along with the biochemical data, proved that both the  $\alpha$  and  $\beta$  subunits of PEBP2 are indispensable for its in vivo function. On the other hand, partial knockout mice were independently generated by deleting exon 5 encoding the C-terminal 32 amino acid from the  $\beta$  gene (Sasaki et al., 1996; Wang et al., 1996b). Even though the disruption of this exon does not affect the production of  $\beta$ 3 protein, the homozygous mutation resulted in the same spectrum of abnormalities as seen with the *Pebp2 $\beta$*  null knockout mutation. One explanation is that  $\beta$ 3 is not functional in vivo. On the other hand, if  $\beta$ 3 is functional in vivo, then an insufficient amount of  $\beta$ 3 protein, lower than the threshold level, could be responsible for the resulting phenotypes. The important function of PEBP2 gene in hematopoiesis has also been demonstrated in *Xenopus* system. Analysis of *Xaml* (*Xenopus* homolog of *AML1*) expression and function suggested that PEBP2 is required for the development of all blood lineages and may function in the early formation of hematopoietic stem cell (Tracey et al., 1998).

It has been demonstrated that *Pebp2 $\alpha$ A/Cbfa1*, another *Pebp2 $\alpha$*  gene, plays an essential role in osteogenesis. Mice with a homozygous mutation in  $\alpha$ A died just after birth due to breathing inability caused by a complete lack of ossification (Komori et al., 1997; Otto et al., 1997). Both intramembranous and endochondral ossification were completely blocked owing to the maturational arrest of osteoblasts in the mutant mice. Northern blot analysis from bone in homozygous  $\alpha$ A(-/-) mice confirmed the extremely low expression of osteoblast-specific genes (*alkalinephosphatase*, *osteopontin*, and *osteocalcin*). Exogenous expression of  $\alpha$ A in MC3T3 calvarial cells, which are committed to the osteoblast lineage but do not express any osteoblast-specific genes under normal culture conditions, induced *Bsp*, *Osteocalcin* and  *$\alpha$ 1(I) collagen* expression (Ducy et al., 1997). These results strongly suggest that the  $\alpha$ A transcription factor is essential for osteoblast differentiation. The  $\alpha$ A gene is also involved in human disease. In  $\alpha$ A(+/-) heterozygous mice, Otto et al. noticed certain abnormalities, the most prominent of

which was hypoplasia of the clavicle and delayed development of membranous bones. These results suggest haplotype insufficiency of  $\alpha A$  for membranous but not endochondral ossification. These phenotypes are a typical feature of human disease called cleidocranial dysplasia (CCD), an autosomal dominant disorder. Human CCD maps to 6p21 (Mundlos et al., 1995) where the  $\alpha A$  is localized (Levanon et al., 1994; Zhang et al., 1997). Interestingly, there is another mouse model that also shows close similarities to human CCD (Selby and Selby, 1978) and the mutation was mapped to chromosome 17 in the same region of the mouse  $\alpha A$  gene (Bae et al., 1994; Hamvas et al., 1996). Together with these results and detection of deletions, insertions and mutations that inactivated one allele of  $\alpha A$  gene from CCD patients, the lack of expression of one allele of the  $\alpha A$  gene was deemed to be the basis of CCD

syndrome in humans (Lee et al., 1997; Mundlos et al., 1997).

#### Dimerization and subcellular localization of PEBP2

By transiently expressing cDNAs in NIH3T3 cells, the  $\alpha$  subunits of PEBP2 encoded by all three genes are found to be localized to the nucleus. The nuclear localization signal (NLS), consisting of a basic amino acid cluster, is located around the C-terminal boundary of the Runt domain (Kanno et al., 1998a; Thirunavukkarasu et al., 1998). The  $\beta$  subunit, on the other hand, is a cytoplasmic protein when it is not complexed with the  $\alpha$  subunit. Unexpectedly, the heterodimerization of the  $\alpha$  and  $\beta$  subunit does not seem to occur readily. Most of  $\alpha$  and  $\beta$  subunits transiently co-expressed in murine fibroblast do not form heterodimers:

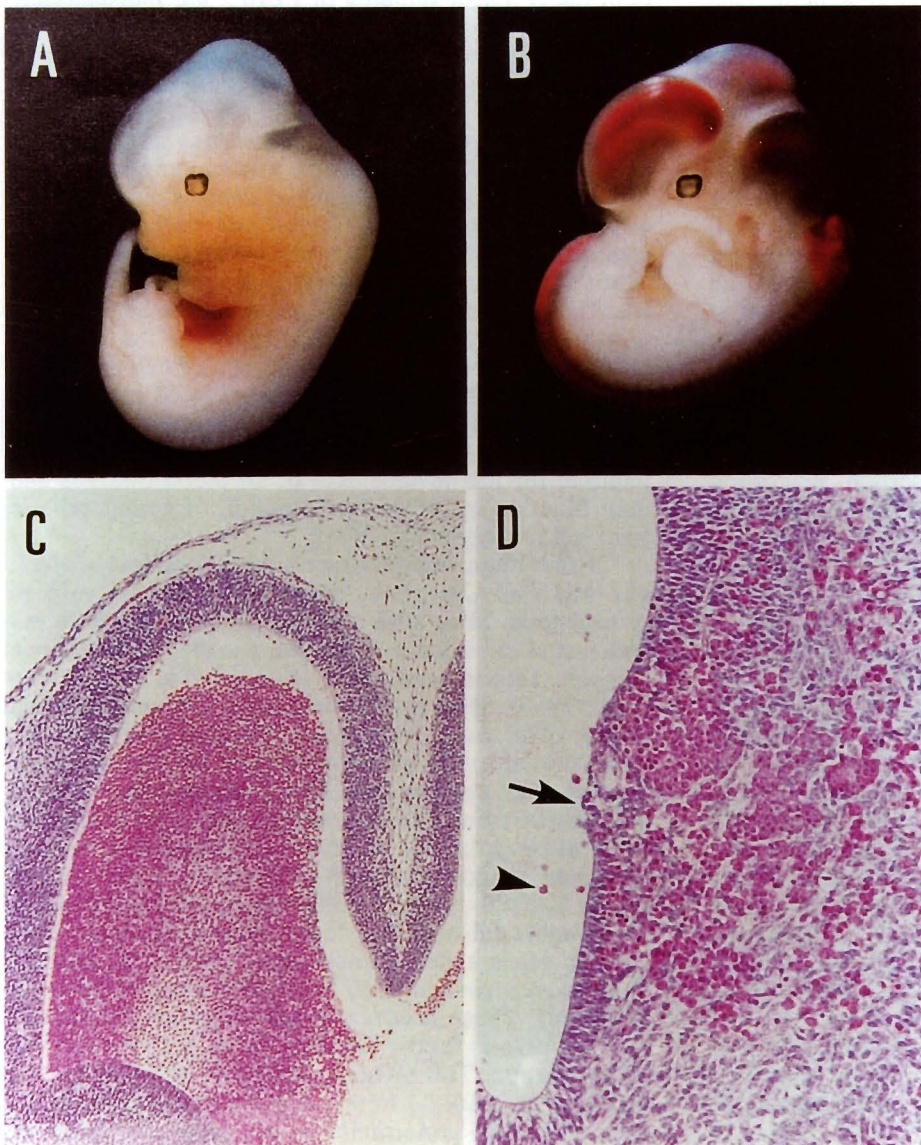

**Fig. 3.** Gross and microscopic view of the hemorrhagic lesion in E12.5 *Pebp2B*  $(-/-)$  embryos (Niki et al., 1997). **A.** *Pebp2B*  $(+/-)$  embryo. **B.** Severe hemorrhage of  $(-/-)$  embryo. **C.** An enlarged view of the hemorrhage in the lateral ventricle of a  $(-/-)$  embryo. x 20. **D.** Histological view of isthmus of a  $(-/-)$  embryo. These results are essentially the same as those obtained with *Pebp2 $\alpha$ B/Aml*  $(-/-)$  embryo. x 100

the  $\alpha$  subunit is localized to the nucleus and the  $\beta$  subunit remains in the cytoplasm (Lu et al., 1995). However, the  $\beta$  protein can be translocated into the nucleus when it is expressed with either the N- or C-terminally truncated form of the  $\alpha$  protein (Fig. 4). These results suggest that the N- and C-terminal regions of the  $\alpha$  subunit flanking the Runt domain inhibit association with the  $\beta$  subunit *in vivo* and that removal of one of these regions suffices for

heterodimerization with the  $\beta$  protein. Therefore, there must be a specific mechanism to promote dimerization. An attractive model for the control of PEBP2 site-dependent transcription activation would be that association between the two subunits of PEBP2, which presumably takes place in the cytoplasm, is rate-limiting. Although the  $\alpha$  protein alone can enter the nucleus and bind to DNA *in vitro*, this DNA binding is extremely

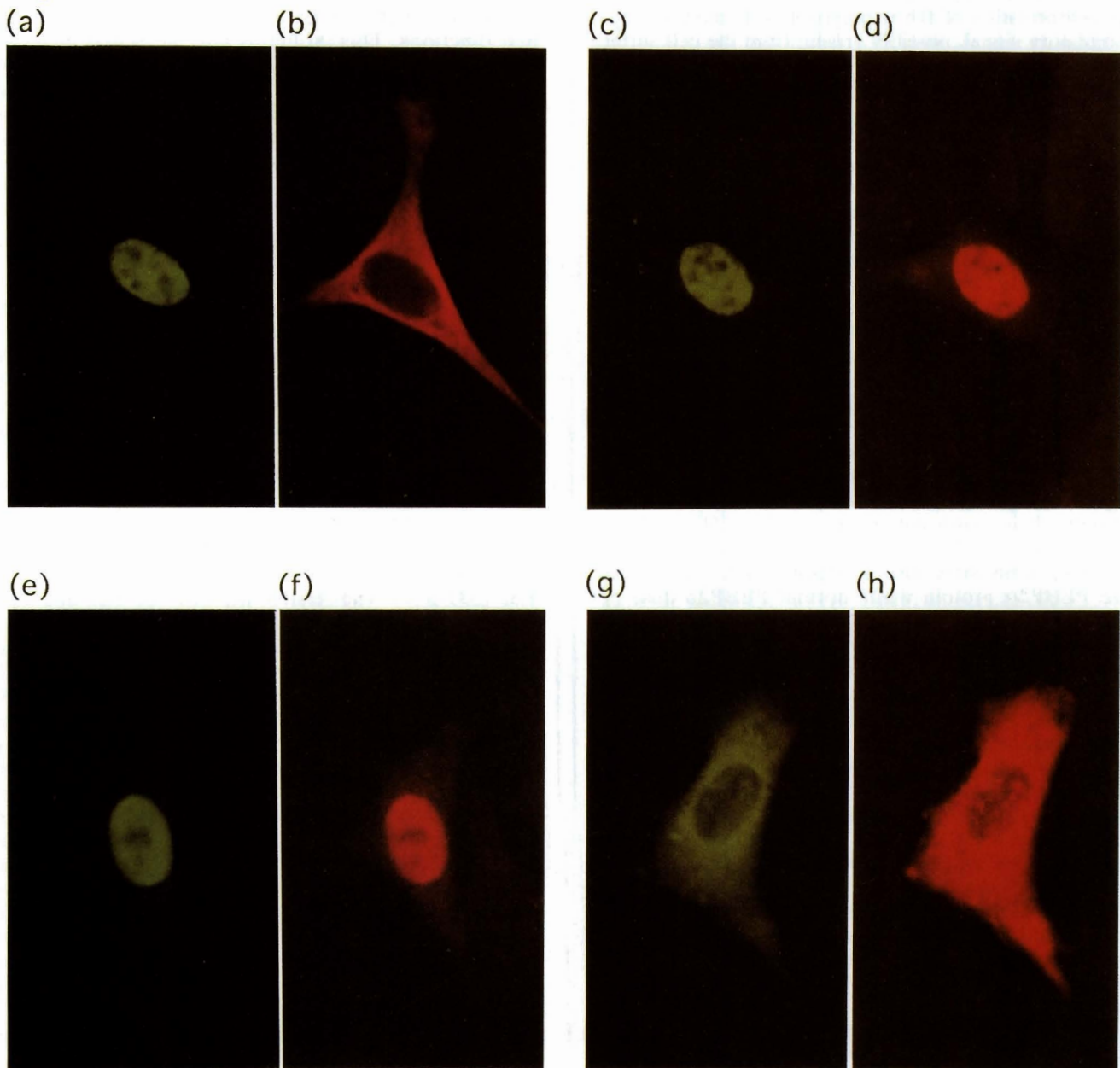

**Fig. 4.** Double fluorescence labeling of the NIH3T3 cells cotransfected with the expression plasmids for PEBP2 $\alpha$ 1 or its deletion derivatives and PEBP2 $\beta$ 2 (Lu et al., 1995). **a and b.**  $\alpha$ 1 and  $\beta$ 2 plasmids. **c and d.** N-terminal truncated form of  $\alpha$ 1 (94-513) and  $\beta$ 2 plasmids. **e and f.** C-terminal truncated form of  $\alpha$ 1 (1-226) and  $\beta$ 2 plasmids. **g and h.** C-terminal truncated form of  $\alpha$ 1 (1-93) and  $\beta$ 2 plasmids. **a, c, e and g.** Detection of FITC-conjugated antibody against rabbit IgG with a 495 nm wavelength filter. **b, d, f and h.** Detection of rhodamine-conjugated antibody against hamster IgG with a 555 nm wavelength filter. See figure 1 for the amino acid numbers.  $\times 400$

weak and may not be physiologically meaningful in terms of transcription activation. Moreover, surprisingly similar phenotypes resulted from the disruption of *PeBP2 $\alpha$ B/Aml1* and *PeBP2 $\beta$*  suggesting that heterodimerization of the two subunits is essential for PEBP2 function in vivo. In order for PEBP2 to function, therefore, the  $\alpha/\beta$  heterodimer must be formed. Under physiological conditions, the inhibitory effect of the flanking regions would probably be relieved by some kind of protein modification. It is enticing to suggest that the conformation of the  $\alpha$  polypeptide is modified by a stimulatory signal, possibly arising from the cell surface receptors, which would modify the  $\alpha$  protein in such a way as to associate with the  $\beta$  protein. This would then activate PEBP2 site-dependent transcription. In relation to this, it is particularly interesting to note that the regulatory C-terminal region of AML1/ $\alpha$ B is always absent in the chimeric protein AML1-ETO generated as a result of t(8;21) chromosome translocation. There is also a possibility that conformational changes occur on the  $\beta$  subunit moiety to stimulate heterodimerization. Interestingly, heterozygous mice having targeted insertion of *AML1-ETO* or *PEBP2/CBFB-MYH11* (encoding  $\beta$ -SMMHC protein), generated as a result of the t(8;21) and inversion 16, respectively, displayed phenotypes similar to those of the corresponding targeted homozygous mutations (Castilla et al., 1996; Yergeau et al., 1997; Okuda et al., 1998). This indicates that both chimeric proteins can act as dominant negative effectors. The dominant activity could also be elicited by signal-independent heterodimerization of  $\alpha$  and  $\beta$  subunits. It is worth noting that AML1-ETO is able to accumulate PEBP2 $\beta$  in the nucleus (Tanaka et al., 1998). Likewise,  $\beta$ -SMMHC also heterodimerizes with the full-size PEBP2 $\alpha$  protein while normal PEBP2 $\beta$  does not (Lu et al., 1995).  $\beta$ -SMMHC protein contains an intact dimerization domain and an alpha helical rod domain that forms coiled-coil dimers and higher order bipolar myosin filaments. Kanno and colleagues extended the study by showing that  $\beta$ -SMMHC dominantly binds to the  $\alpha$  subunit, tethering it to the cytoskeleton and impeding its nuclear translocation (Kanno et al., 1998b). Co-expression studies of  $\alpha\beta$  fused to the glucocorticoid receptor ligand-binding domain and  $\beta$ -SMMHC has demonstrated that  $\beta$ -SMMHC sequesters the  $\alpha$  subunit in the cytoplasm and blocks dexamethasone-dependent nuclear translocation of the  $\alpha$  subunit. It has been shown that the level of *Cbfa2/ $\alpha$ B* is limiting in hematopoietic progenitor cells while the level of  $\beta$  is saturating. A consistent mild dosage effect was observed for the heterozygous mutation of the *Cbfa2/ $\alpha$ B* gene but not for that of  $\beta$  gene (Wang et al., 1996a). Therefore, signal-independent heterodimerization and tethering activity of  $\beta$ -SMMHC may explain why heterozygous  $\beta$ -MYH11 knock-in mice display an almost identical phenotype to mice with a homozygous disruption of *Cbfa2/ $\alpha$ B*. The ability of  $\beta$ -SMMHC to heterodimerize readily with the  $\alpha$  subunit and sequester it away from the nucleus may be one of the factors determining the leukemogenic

potential of  $\beta$ -MYH11.

#### Negative regulatory domain for DNA binding (NRg (NRDB))

PEBP2 $\alpha$ B/AML1 has a modular structure. Several distinct functional domains are recognized throughout the molecule. The central part of AML1 corresponds to the evolutionarily conserved Runt domain, required for DNA binding and heterodimerization. The Runt domain of the full length AML1/ $\alpha$ B1 protein is inert for these two functions. This is due to intramolecular negative regulation. The DNA binding activity is masked by the region between 184 and 291 (Fig. 1). Unless this region is removed by either introducing a deletion or by some other mechanisms, the Runt domain will not bind to DNA. This autoinhibitory domain of AML1 has been termed NRDB (negative regulatory domain for DNA binding). The presence of NRDB was demonstrated by examining the DNA binding abilities of the C-terminally truncated AML1 with 1-183 and 1-291, or with 50-183 and 50-291 (Kanno et al., 1998a). The N-terminal 49 amino acids also inhibit the DNA binding ability of the Runt domain. Therefore, the presence of NRDB is more clearly apparent when the N-terminal 49 amino acids are removed. The interaction of the Runt domain with the  $\beta$  subunit is also autoinhibited by the C-terminal region. Although the boundary has not been precisely mapped, the region between 411 and 446, appears to be responsible for impeding  $\beta$  subunit interaction with the Runt domain. The C-terminal Pro, Ser and Thr rich region of AML1 also harbors a weak but intrinsic transactivation domain (AD) between 291 and 371. This can be subdivided into two regions: TE1 (291-331) and TE2 (331-371). The relative activities of TE1 and TE2 depend very much on the cell type and the nature of the promoter used to measure their activity. It was suggested that different transcription-related proteins interact with these regions. Recently, transcriptional co-activator p300 was shown to interact with this region (Kitabayashi et al., 1998). The activities of TE1 and TE2 are completely inhibited by the adjacent region 371-411. This 40 amino acid-region, termed ID (inhibitory domain), does not show positive repressor activity when it is fused to GAL4 DNA binding domain. Therefore, it is likely that ID physically masks AD to inhibit the transactivation function. It will be interesting to see whether masking by ID prevents the interaction of transcription-related proteins to AD. Thus, AML1 protein appears to be non-functional by itself unless some specific activation mechanism intervenes to allow heterodimerization with the  $\beta$  subunit and binding to DNA. Furthermore, AD would also need to be opened if it is to become active as a transcription factor. How is this achieved? Experimentally, deletion of the C-terminal region was shown to promote heterodimerization. It appears that, once heterodimerization with the  $\beta$  subunit is achieved, AML1 is able to bind to DNA. In other words, binding of the  $\beta$  subunit to the Runt domain induces structural

changes in the Runt domain so that the effect of NRDB is eliminated. Recently, an interesting observation was made concerning regulation of heterodimerization. It is known that binding sites of AML1 and Ets-1 are often found in the regulatory regions of T cell specific genes, such as T-cell receptors  $\alpha$  and  $\beta$  (TCR  $\alpha$  and  $\beta$ ). Furthermore, direct physical interaction between Ets-1 and PEBP2 $\alpha$ A has been observed (Giese et al., 1995). We recently showed that Ets-1 and AML1/ $\alpha$ B also directly interact. Using TCR $\beta$  enhancer, the interaction between AML1/ $\alpha$ B and Ets-1 was studied in detail (Kim and Ito, submitted). The first major observation is that AML1 and Ets-1 can bind to DNA cooperatively in the absence of the  $\beta$  subunit. Once these two proteins interact, the  $\beta$  subunit is then able to interact with the Runt domain and stably bind to DNA. Interaction of the two proteins occurs at multiple sites on both proteins. However, there is only one region on each protein which is primarily responsible for cooperative DNA binding. The critically important region for protein-protein interaction on AML1 lies within NRDB. When Ets-1 interacts with NRDB, the Runt domain is exposed to DNA, presumably as a result of Ets-1 partitioning of the NRDB away from the DNA. Furthermore, the interface of the Runt domain responsible for interaction with the  $\beta$  subunit is also unmasked simultaneously, allowing the  $\beta$  to interact with the Runt domain. It is tempting to speculate that there may be a switch within NRDB. If the switch were properly set in the on position by protein-protein interaction, the two interfaces of the Runt domain could be simultaneously opened, which would permit DNA-binding and heterodimerization. It will be important to determine if there exist still other elements besides Ets-1 capable of opening the AML1 molecule.

### Future prospects

Homozygous mutations of  $\alpha$ A and  $\alpha$ B in the mouse show a block in osteoblast development from the mesenchyme stage and a total lack of hematopoiesis in the fetal liver, respectively. Considering the essential roles of PEBP2 genes in the development of corresponding tissues, it is very important to understand how PEBP2 activity is regulated. Previous observations suggest that there are at least two types of regulatory mechanisms: One is at the level of transcription and the other is at the level of post-translational modification. Tissue-specific expression of these genes must be regulated at the transcriptional level. Since the expression of PEBP2 $\alpha$  genes is essential for the decision of cell fate during the early stages of mouse development, it will be important to first understand the transcriptional regulation mechanism of  $\alpha$  genes. Homozygous mutation of *Pebp2 $\beta$*  resulted in the same phenotype seen in  $\alpha$ B-deficient mice. These results strongly indicate that  $\beta$  is essential for  $\alpha$ B function in vivo. These results do not mean that  $\alpha$ A and  $\alpha$ C function in the absence of  $\beta$  subunit but most likely indicate that, of the three  $\alpha$  genes,  $\alpha$ B is the first gene to

function during mouse development since PEBP2 $\alpha$  subunits contain almost identical Runt domains harboring heterodimerization activity. As mentioned above, although dimerization of  $\alpha$  and  $\beta$  subunits is essential for the normal function of PEBP2, dimerization does not seem to occur readily in vivo. This leads to the question of how the heterodimerization of  $\alpha$  and  $\beta$  subunits is regulated. To understand more about the role of PEBP2 in hematopoiesis and osteogenesis, it is essential to identify the mechanisms regulating the activities of PEBP2.

*Acknowledgments.* We are very grateful to all our colleagues and collaborators who have made this work possible. This study was supported by a Genetic Engineering Research Grant (GE-96-102) from the Ministry of Education, and a grant from the Good Health R & D project (HMP-96-M-2-1068) from the Ministry of Health and Welfare, Korea.

### References

- Bae S-C., Ogawa E., Maruyama M., Oka H., Satake M., Shigesada K., Jenkins N.A., Gilbert D.J., Copeland N.G. and Ito Y. (1994). PEBP2 $\alpha$ B/ mouse AML1 consists of multiple isoforms that possesses differential transactivation potentials. *Mol. Cell. Biol.* 14, 3242-3252.
- Bae S-C., Takahashi E., Zhang Y.W., Ogawa E., Shigesada K., Namba Y., Satake M. and Ito Y. (1995). Cloning, mapping and expression of PEBP2 $\alpha$ C, a third gene encoding the mammalian Runt domain. *Gene* 159, 245-248.
- Bae S-C., Yamaguchi-Iwai Y., Ogawa E., Maruyama M., Inuzuka M., Kagoshima H., Satake M. and Ito Y. (1993). Isolation of PEBP2 $\alpha$ B cDNA representing the mouse homolog of human acute myeloid leukemia gene AML1. *Oncogene* 8, 809-814.
- Castilla L.H., Wijmenga C., Wang Q., Stacy T., Speck N.A., Eckhaus M., Marin-Padilla M., Collins F.S., Wynshaw-Boris A. and Liu P.P. (1996). Failure of embryonic hematopoiesis and lethal hemorrhages in mouse embryos heterozygous for a knocked-in leukemia gene *CBFB-MYH11*. *Cell* 87, 687-696.
- Daga A., Karlovich C.A., Dumstrei K. and Banerjee J. (1996). Patterning of cells in the Drosophila eye by Lozenge, which shares homologous domain with AML1. *Genes Dev.* 10, 1194-1205.
- Ducy P., Zhang R., Geoffroy V., Ridall A.L. and Karsenty G. (1997). *Osf2/Cbfa1*: a transcriptional activator of osteoblast differentiation. *Cell* 89, 747-754.
- Duffy J.B. and Gergen J.P. (1991). The Drosophila segmentation gene *runt* acts as a position-specific numerator element necessary for the uniform expression of the sex determining gene, *Sex-lethal*. *Genes Dev.* 5, 2176-2187.
- Duffy J.B., Kania M.A. and Gergen J.P. (1991). Expression and function of the Drosophila gene *runt* in early stages of neural development. *Development* 113, 1223-1230.
- Erickson P., Gao J., Chang K.S., Look T., Whisenant E., Raimondi S., Lasher R., Trujillo J., Rowley I. and Drabkin H. (1992). Identification of breakpoints in t(8;21) acute myelogenous leukemia and isolation of a fusion transcript, AML1/ETO, with similarity to Drosophila segmentation gene, *runt*. *Blood* 80, 825-1831.
- Flores G.V., Daga A., Kalhor H.R. and Banerjee U. (1998). Lozenge is

*Heterodimeric transcription factor, PEBP2/CBF*

- expressed in pluripotent precursor cells and patterns multiple cell types in the drosophila eye through the control of cell-specific transcription factors. *Development* 125, 3681-3687.
- Fujioka M., Yusibova G.L., Sackerson C.M., Tillib S., Mazo A., Satake M. and Goto T. (1996). Runt domain partner proteins enhance DNA binding and transcriptional repression in cultured *Drosophila* cells. *Genes Cells* 1, 741-754.
- Gergen J.P. and Wieschaus E. (1985). The localized requirement for a gene affecting segmentation in *Drosophila*: analysis of larvae mosaic for *runt*. *Dev. Biol.* 109, 321-335.
- Gergen J.P. and Wieschaus E. (1986). Dosage requirements for *runt* in the segmentation of *Drosophila* embryos. *Cell* 45, 289-299.
- Giese K., Kingsley C., Kirshner J.R. and Grosschedl R. (1995). Assembly and function of a TCR alpha enhancer complex is dependent on LEF-1-induced DNA bending and multiple protein-protein interactions. *Genes Dev.* 9, 995-1008.
- Golling G., Li L.H., Pepling M., Stabbins M. and Gergen J.P. (1996). *Drosophila* homologs of the proto-oncogene product PEBP2/CBF $\beta$  regulate the DNA-binding properties of Runt. *Mol. Cell. Biol.* 16, 932-942.
- Golub T.R., Barker G.F., Bohlander S.K., Ward D.C., Bary-Ward P., Morgan E., Raimondi S.C., Rowley J.D. and Gilliland D.G. (1995). Fusion of the *TEL* gene on 12p13 to the *AML1* gene on 21q22 in acute lymphoblastic leukemia. *Proc. Natl. Acad. Sci. USA* 92, 4917-4921.
- Hamvas R., Trachtulec Z., Forejt J., Williams R.W., Arzt K., Fischer-Lindahl K. and Silver L.M. (1996). Encyclopedia of the mouse genome V. Mouse chromosome 17. *Mamm. Genome* 6, S281-S299.
- Ito Y. and Bae S-C. (1997). Oncogenes as Transcription Regulator. In: *The Runt domain transcription factor, PEBP2/CBF, and its involvement in human leukemia*. Yaniv M. and Ghysdael J. (eds). Birkhauser Basel/Switzerland. Vol. 2. pp107-132.
- Kagoshima H., Satake M., Miyoshi H., Ohki M., Pepling M., Gergen P., Shigesada K. and Ito Y. (1993). The Runt domain identifies a new family of heterodimeric transcriptional regulators. *Trends Genet.* 9, 338-341.
- Kania M.A., Bonner A.S., Duffy J.B. and Gergen J.P. (1990). The *Drosophila* segmentation gene *runt* encodes a novel nuclear regulatory protein that is also expressed in the developing nervous system. *Genes Dev.* 4, 1701-1713.
- Kanno T., Kanno Y., Chen L-F., Ogawa E., Kim W-Y. and Ito Y. (1998a). Intrinsic transcriptional activation-inhibition domain of the polyomavirus enhancer binding protein 2/core binding factor  $\alpha$  subunit revealed in the presence of the  $\beta$  subunit. *Mol. Cell. Biol.* 18, 2444-2454.
- Kanno Y., Kanno T., Sakakura C., Bae S-C. and Ito Y. (1998b). Cytoplasmic sequestration of the polyomavirus enhancer binding protein 2 (PEBP2)/Core binding factor  $\alpha$  (CBF $\alpha$ ) subunit by the leukemia-related PEBP2/CBF $\beta$ -SMMHC fusion protein inhibits PEBP2/CBF mediated transactivation. *Mol. Cell. Biol.* 18, 4252-4261.
- Kitabayashi I., Yokoyama A., Shimizu K. and Ohki M. (1998). Interaction and functional cooperation of the leukemia-associated factors AML1 and p300 in myeloid cell differentiation. *EMBO J.* 17, 2994-3004
- Kogan S.C., Lagasse E., Atwater S., Bae S-C., Weissman I., Ito Y. and Bishop J.M. (1998). The PEBP2 $\beta$ etamyh11 fusion created by Inv(16)(p13;q22) in myeloid leukemia impairs neutrophil maturation and contributes to granulocytic dysplasia. *Proc. Natl. Acad. Sci. USA* 95, 11863-11868.
- Komori T., Yagi H., Nomura S., Yamaguchi A., Sasaki K., Deguchi K., Shimizu, Y., Bronson R.T., Gao Y-H., Inada M., Sato M., Okamoto R., Kitamura Y., Yoshiaki S. and Kishimoto T. (1997). Targeted disruption of *Cbfa1* results in a complete lack of bone formation owing to maturational arrest of osteoblasts. *Cell* 89, 755-764.
- Lee B., Thirunavukkarasu K., Zhou L., Pastore L., Baldini A., Hecht J., Geoffroy V., Ducy P. and Karsenty G. (1997). Missense mutations abolishing DNA binding of the osteoblast-specific transcription factor OSF2/CBFA1 in cleidocranial dysplasia. *Nat. Genet.* 15, 303-306.
- Levanon D., Negreanu V., Bernstein Y., Bar-Am I., Avivi L. and Groner Y. (1994). AML1, AML2, and AML3, the human members of the runt domain gene-family: cDNA structure, expression, and chromosomal localization. *Genomics* 23, 425-432.
- Liu P., Tarle S.A., Hajra A., Claxton D.F., Marlton P., Freedman M., Siciliano M.J. and Collins F.S. (1993). Fusion between transcription factor CBF beta/PEBP2 beta and a myosin heavy chain in acute myeloid leukemia. *Science* 261, 1041-1044.
- Liu P.P., Hajra A., Wijmenga C. and Collins F.S. (1995). Molecular pathogenesis of the chromosome 16 inversion in the M4Eo subtype of acute myeloid leukemia. *Blood* 85, 2289-2302.
- Lu J., Maruyama M., Satake M., Bae S-C., Ogawa E., Kagoshima H., Shigesada K. and Ito Y. (1995). Subcellular localization of the  $\alpha$  and  $\beta$  subunit of the acute myeloid leukemia-linked transcription factor PEBP2/CBF. *Mol. Cell. Biol.* 15, 1651-1661.
- Melnikova I.N., Crute B.E., Wang S. and Speck N.A. (1993). Sequence specificity of the core-binding factor. *J. Virol.* 67, 2408-2411.
- Meyers S., Downing J.R. and Hiebert S.W. (1993). Identification of AML-1 and the (8;21)translocation protein (AML-1/ETO) as sequence-specific DNA-binding proteins: the runt homology domain is required for DNA binding and protein-protein inter-actions. *Mol. Cell. Biol.* 13, 6336-6345.
- Miyoshi H., Shimizu K., Kozu T., Maseki N., Kaneko Y. and Ohki M. (1991). t(8;21) breakpoints on chromosome 21 in acute myeloid leukemia are clustered within a limited region of a single gene, *AML1*. *Proc. Natl. Acad. Sci. USA* 88, 10431-10434.
- Miyoshi H., Ohira M., Shimizu K., Enomoto K., Maseki N., Kaneko Y., Kamada N. and Ohki M. (1993). The t(8;21) translocation acute myeloid leukemia results in production of an AML1-MTG8 fusion transcript. *EMBO J.* 12, 2715-2721.
- Mundlos S., Mulliken J.B., Abramson D.L., Warman M.L., Knoll J.H. and Olsen B.R. (1995). Genetic mapping of cleidocranial dysplasia and evidence of a microdeletion in one family. *Hum. Mol. Genet.* 4, 71-75.
- Mundlos S., Otto F., Mundlos C., Mulliken J.B., Aylsworth A.S., Albright S., Lindhout D., Coel W.G., Mertelsman R., Zabel B.U. and Olsen B.R. (1997). Mutation involving the transcription factor *CBFA1* causes cleidocranial dysplasia. *Cell* 89, 773-779.
- Niki M., Okada H., Takano H., Kuno J., Tani K., Hibino H., Asano S., Ito Y., Satake M. and Noda T. (1997). Hematopoiesis in the fetal liver is impaired by targeted mutagenesis of a gene encoding a non-DNA binding subunit of the transcription factor, polyomavirus enhancer binding protein 2/core binding factor. *Proc. Natl. Acad. Sci. USA* 94, 5697-5702.
- Nucifora G. and Rowley J.D (1995). AML1 and the 8;21 and 3;21 translocation in acute and chronic myeloid leukemia. *Blood* 86, 1-14.
- Ogawa E., Inuzuka M., Maruyama M., Satake M., Naito-Fujimoto M., Ito Y. and Shigesada K. (1993a). Molecular cloning and characterization of PEBP2 $\beta$ , the heterodimeric partner of a novel *Drosophila* runt-related DNA binding protein PEBP2 $\alpha$ . *Virology* 194,



## Heterodimeric transcription factor, PEBP2/CBF

- 314-331.
- Ogawa E., Maruyama M., Kagoshima H., Inuzuka M., Satake M., Shigesada K. and Ito Y. (1993b). PEBP2/PEBP2 represents a family of transcription factors homologous to the products of the *Drosophila runt* gene and human *AML1* gene. *Proc. Natl. Acad. Sci. USA* 90, 6859-6863.
- Okuda T., Cai Z., Yang S., Lenny N., Lyu C.J., van Deursen J.M., Harada H. and Downing J.R. (1998). Expression of a knocked-in *AML1-ETO* leukemia gene inhibits the establishment of normal definitive hematopoiesis and directly generates dysplastic hematopoietic progenitors. *Blood* 91, 3134-3143.
- Okuda T., van Deursen J., Hiebert S.W., Grosveld G. and Downing J.R. (1996). *AML1*, the target of multiple chromosomal translocations in human leukemia, is essential for normal fetal liver hematopoiesis. *Cell* 84, 321-330.
- Otto F., Thornell A.P., Crompton T. and Owen M.J. (1997). *Cbfa1*, a candidate gene for cleidocranial dysplasia syndrome, is essential for osteoblast differentiation and bone development. *Cell* 89, 765-771.
- Romana S.P., Mauchauffe M., Le Coniat M., Chumakov I., Le Paslier D., Berger R. and Bernard O.A. (1995). The t(12;21) of acute lymphoblastic leukemia results in a *tel-AML1* gene fusion. *Blood* 85, 3662-3670.
- Sasaki K., Yagi H., Bronson R.T., Tominaga K., Matsunashi T., Deguchi K., Tani Y., Kishimoto T. and Komori T. (1996). Absence of fetal liver hematopoiesis in mice deficient in transcriptional coactivator core binding factor beta. *Proc. Natl. Acad. Sci. USA* 93, 12359-12363.
- Selby P.B. and Selby P.R. (1978). Gamma-ray-induced dominant mutation that cause skeletal abnormalities in mice. Disruption of proved mutations. *Mut. Res.* 51, 199-236.
- Speck N.A. and Stacy T. (1995) A new transcription factor family associated with human leukemias. *Crit. Rev. Euk. Gene* 5, 337-364.
- Tanaka K., Tanaka T., Kurokawa M., Imai Y., Ogawa S., Mitani K., Yazaki Y. and Hirai H. (1998). The *AML1/ETO*(MTG8) and *AML1/Evi-1* leukemia-associated chimeric oncoproteins accumulate PEBP2beta(CBFbeta) in the nucleus more efficiently than wild-type *AML1*. *Blood* 91, 1688-1699.
- Thirunavukkarasu K., Mahajan M., McLaren K.W., Stifani S. and Karsenty G. (1998). Two domains unique to osteoblast-specific transcription factor *Osf2/Cbfa1* contribute to its transactivation function and its inability to heterodimerize with *Cbfbeta*. *Mol. Cell. Biol.* 18, 4197-4208.
- Tracey W.D. Jr, Pepling M.E., Horb M.E., Thomsen G.H. and Gergen J.P. (1998). A *Xenopus* homologue of *aml-1* reveals unexpected patterning mechanisms leading to the formation of embryonic blood. *Development* 125, 1371-1380.
- Wang Q., Stacy T., Binder M., Matine-Padilla M., Sharpe A.H. and Speck N.A. (1996a). Disruption of the *cbfa2* gene causes necrosis and hemorrhaging in the central nervous system and blocks definitive hematopoiesis. *Proc. Natl. Acad. Sci. USA* 92, 3444-3449.
- Wang Q., Stacy T., Miller D.J., Lewis A.F., Gu T-L., Huang X., Bushweller J.H., Boris J-C., Alt F.W., Ryan G., Liu P.P., Winshow-Boris A., Binder M., Marin-Padilla M., Sharp A.H. and Speck N.A. (1996b). The CBF $\beta$  subunit is essential for CBF $\alpha$ 2(*AML1*) function in vivo. *Cell* 87, 697-708.
- Wang S., Wang Q., Crute B.E., Melnikova I.N., Keller S.R. and Speck N.A. (1993). Cloning and characterization of subunits of the T-cell receptor and murine leukemia virus enhancer core-binding factor. *Mol. Cell. Biol.* 13, 3324-3339.
- Wotton D., Ghysdael J., Wang S., Speck N.A. and Owen M.J. (1994). Cooperative binding of *Ets-1* and core binding factor to DNA. *Mol. Cell. Biol.* 14, 840-850.
- Yergeau D.A., Hetherington C.J., Wang Q., Zhang P., Sharpe A.H., Binder M., Marin-Padilla M., Tenen D.G., Speck N.A. and Zhang D.E. (1997). Embryonic lethality and impairment of haematopoiesis in mice heterozygous for an *AML1-ETO* fusion gene. *Nat. Genet.* 16, 307-310.
- Zhang W-W., Bae S-C., Takahashi E-I. and Ito Y. (1997). A cDNA cloning of the transcripts of human *PEBP2 $\alpha$ /CBFA1* mapped to 6p12.3-p21.1, the locus for cleidocranial dysplasia. *Oncogene* 15, 367-371.

Accepted March 4, 1999