

## Self-efficacy among university faculty: how to develop an adjusted scale

María Vera<sup>1\*</sup>, Marisa Salanova<sup>1</sup>, and Beatriz Martín-del-Río<sup>2</sup>

<sup>1</sup> Universitat Jaume I (Spain)

<sup>2</sup> Universidad Miguel Hernández de Elche (Spain)

**Título:** Autoeficacia en profesores universitarios: cómo desarrollar una escala específica

**Resumen:** El objetivo de este estudio fue mostrar el procedimiento llevado a cabo para desarrollar una escala que midiese la autoeficacia específica en un dominio, por ejemplo, en el personal docente e investigador de la universidad, siguiendo las recomendaciones de la *Teoría Social Cognitiva* de Albert Bandura. La escala creada considera el triple perfil laboral de los profesores universitarios (docencia, investigación y gestión). Mediante el uso del análisis factorial confirmatorio en una muestra de 166 profesores universitarios, encontramos un ajuste superior en el modelo de tres factores que se corresponden con el triple perfil laboral. Además, hemos encontrado diferencias significativas en la autoeficacia para la investigación en el nivel de formación académica, a medida que el nivel de educación académica aumenta, la autoeficacia también lo hace. Por último, son discutidas las implicaciones teóricas y prácticas, las limitaciones del estudio y las futuras investigaciones.

**Palabras claves:** Autoeficacia; escala; profesores universitarios.

**Abstract:** The aim of this study was to describe the procedure carried out to develop a scale to measure specific self-efficacy in one particular domain, i.e. university faculty, following the recommendations from *Social Cognitive Theory* by Albert Bandura. The scale that was created considers the triple work profile of university faculty (i.e. teaching, research and management). By using confirmatory factor analyses in a sample of 166 university faculty members, we found a superior fit for the three-factor model that corresponded with their triple work profile. Moreover, we found significant differences in research self-efficacy at the level of academic education: as the level of academic education increases, self-efficacy also increases. Finally, theoretical and practical implications, limitations of the study and future research are also discussed.

**Key words:** Self-efficacy scale; University faculty.

### Introduction

Efficacy beliefs are the beginning of the route that we wish to embark upon. What we decide to do, the persistence that we display in it and our decision to give up or to carry on depend to a large extent on the “beliefs in one’s own capacities to organise and execute the courses of action required to produce certain results” (Bandura, 1997, p. 3).

Depending on how we see the horizon, we will walk. But when we begin, we do not start out from a void: we have previous knowledge that modulates how we evaluate the route. Bandura (1997) called it sources of efficacy expectations, and postulated four: enactive mastery, vicarious experiences, verbal persuasion, and physiological and affective states.

People with high self-efficacy perceive troubles as challenges, are highly committed to the activities they carry out, invest a lot of time and effort in their activities, think strategically to solve difficulties, recover easily from failure or difficulty, feel they are in control of a majority of stressors and, furthermore, feel they are less vulnerable to stress and depression (Bandura, 1997).

Thus, self-efficacy is a key construct to understand how people feel and perform at work. According to Bandura (1997), self-efficacy is a good predictor of the activities that we decide to carry out, persistence in performance, motivation, and so forth. In the specific case of teaching, Prieto (2002), for instance, considered self-efficacy as playing a pivotal role in the study of university faculty. But to date, teach-

ing self-efficacy has been overlooked in higher education (Burton, Bamberry & Boundy, 2005).

With regard to higher education, university faculty must carry out different kinds of tasks that can be summarised in a triple work profile: teaching, research and management. This triple work profile has already been considered by several authors (Buena-Casal & Sierra, 2007; Chacón, Pérez-Gil, Holgado & Lara, 2001; Cifre, Llorens, Salanova & Martínez, 2003; Currie, 1996; Morrison, 1996; Vera, Salanova & Martín Del Río, 2010).

The study of teacher self-efficacy has always been closely linked with the desire to measure it. Tschannen-Moran, Woolfolk Hoy and Hoy (1998) identified two parallel lines of research in the study of perceived self-efficacy. First, the concept of teacher efficacy was initially used by RAND researchers (Armor et al., 1976). The RAND Corporation conceived teacher efficacy as the extent to which teachers believed they could control the reinforcement of their actions, grounded in *Social Learning Theory* (Rotter, 1966). The second line of research was based on Bandura’s *Social Cognitive Theory* (SCT) and goes beyond the control of the reinforcement of their actions. As we have stated earlier, self-efficacy is the belief in one’s own capacities to organise and execute the courses of action required to produce certain results (Bandura, 1997, p. 3). With this definition as his base, in 1997, Bandura created his own Teacher Self-Efficacy Scale.

Continuing with the desire to measure teacher self-efficacy, several proposals have recently appeared, such as the Teacher Interpersonal Self-Efficacy Scale by Brouwers and Tomic (2001), the Teachers’ Sense of Efficacy Scale by Tschannen-Moran and Woolfolk (2001) which has showed evidence of reliability and measurement invariance across the five countries, i.e., Canada, Cyprus, Korea, Singapore, and the United States (Klassen, et al. 2009), and the Teacher Self-

\* Dirección para correspondencia [Correspondence address]:  
María Vera. Department of Psychology. Universitat Jaume I. 12017  
Castellón (Spain). E-mail: [mvera@psi.uji.es](mailto:mvera@psi.uji.es)

Efficacy Scale by Schwarzer, Schmitz and Daytner (1999). All these questionnaires focus on schoolteachers' self-efficacy and therefore cannot be used to measure self-efficacy in university faculty. The Teacher self-efficacy of university faculty questionnaire, developed by Prieto (2005), is of special interest because it was created to measure teaching self-efficacy in the university context. Although it is a great questionnaire based on the *SCT* theory, it only focuses on one of the university faculty profiles (teaching) and avoids the research and management roles of this population. For us, in order to be able to measure self-efficacy in this population, it is very important to take into account all the work carried out by university faculty as part of their triple work profile.

But we followed Bandura's (2006) advice of creating a specific scale for our domain under study. It is very important to note that self-efficacy is specific to the context that is being measured and not to another. Hence, we must not create a general scale because each domain is different and if general scales were used, our information could be biased. Bandura warns us of the need to conduct an exhaustive study of the domain so that each of the items on our self-efficacy scale reflects the real value of self-efficacy. This author therefore criticised the use of general and non-specific self-efficacy scales, and argued that it is futile to measure self-efficacy with a general scale because the items in tests based on the general efficacy approach are of little or no relevance to the domain being studied. Furthermore, items in a global test are commonly designed in a global fashion and are too ambiguous to allow the researcher to know what is being measured with any degree of accuracy. Self-efficacy scales must be adapted to our particular domain of interest and must reflect a thorough study of our chosen domain.

Bandura (2006) also explained how to develop an adjusted scale for any domain, but that is theory and what we do in this study is practice. Thus, the main objective of this study is to show the procedure carried out to develop an adjusted scale with which to measure specific self-efficacy in one particular domain, i.e. university faculty, following the method and recommendations from the *SCT* by Albert Bandura. In this case, we have created a scale to measure efficacy beliefs in university faculty taking into account the triple work profile. So, although we know how to create a self-efficacy scale (i.e. Bandura, 2006) and this process is similar for many kinds of self-efficacy scales, we show a clear example of how it must be done, explaining all the steps required to create the scale and also testing the results empirically in university faculty.

Moreover, once the scale had been created (and thus the main objective obtained), it was analysed and two secondary objectives appeared. The first one was to test that the scale consisted of three dimensions corresponding to the triple work profile (teaching, research and management), as well as to analyse the psychometric characteristics of the self-efficacy scale. And the second objective was to study whether there were significant differences in self-efficacy

among university faculty with regard to certain variables that had shown significant differences in self-efficacy in other studies in the educational context (i.e. gender, work experience, occupational category, level of academic education, marital status and having children).

With regard to gender, several research studies have shown that women score higher in self-efficacy than men at the different levels of education, and do so most specifically in elementary, special and higher education (Anderson, Greene & Loewen, 1988; Coladarci & Breton, 1997; Raudenbush, Rowen & Cheong, 1992). The relationship between the work experience variable and self-efficacy is unclear, and different studies offer contradictory results. Whereas, in secondary and higher education (Benz, Bradley, Alderman & Flowers, 1992) as well as in student teachers (Hoy & Woolfolk, 1990), indicate that teachers who present a higher degree of self-efficacy are those with little experience. In prekindergarten through 12th-grade teachers (Wolters & Daugherty, 2007) were showed modest effects of experience on self-efficacy. Finally, in elementary and high school teachers, Klassen and Chiu (2010) showed a nonlinear relationship with years of teaching experience; self-efficacy increased from 0 to about 23 years of experience and then declined as years of experience increased. With regard to occupational category, although we did not find studies that took into account differences in self-efficacy in university faculty in relation to occupational category, we did take into account the recommendation by Cifre, Llorens and Salanova (2003), which considered the professional category of these populations at the time of the study. Thus, we bore in mind whether university faculty were state employees or not. As these authors stated, different professional categories (and therefore being a state employee or not) carry different obligations. In relation to levels of academic education, in elementary schools, teachers with a higher level of academic education usually showed greater self-efficacy (Hoy & Woolfolk, 1993). Finally, social support has been proved, in secondary-school teachers, to have an impact on teacher self-efficacy (Brouwers, Evers & Tomic, 2001), which explains our interest in knowing whether marital status and having children influence self-efficacy. For further information about the sociodemographic variables, see Prieto (2002).

## Method

### Participants and procedure

The sample comprised 166 faculty members of a Spanish university, which represents 17.4% of the total number of faculty members of that university ( $N = 955$ ). Basically, Spanish university faculty can be divided into two large groups, state employees (tenured lecturers and university professors) and contract faculty (collaborating staff, part-time lecturers, etc.). In our sample population, we studied 100 contract faculty (60.2%) and 66 state employees (39.8%); 98 were men (59%) and 68 were women (41%); the mean

age was 38.94 years ( $SD = 8.5$ ); 99 were married (59.6%), 27 lived with a partner (16.3%), 24 were single and lived alone (14.5%), nine were single and lived with their parents (5.4%), and seven were divorced/separated (4.2%). A total of 84 had children (50.6%) and 82 did not (49.4%). The level of academic education of the sample was as follows: 105 had completed a doctoral degree, that is, they were PhDs (63.3%); 36 had completed the research aptitude period, that is, the first period prior to obtaining a doctoral degree (21.7%); 22 had a degree which implied long-cycle studies (13.3%) and three had completed a diploma course, implying short-cycle studies (1.8%). As for work experience, 72 had 5 years' experience (43.4%), 50 had between 6 and 10 years' experience (30.1%), 19 had between 11 and 15 years' experience (11.4%), 12 had between 16 and 20 years' experience (7.2%), while 13 had more than 20 years' experience (7.8%).

The person in charge of occupational hazard prevention at the university, along with several members of the research project, sent an envelope to all university faculty members by the internal mail service. The envelope contained a presentation letter, a document which they had to complete with their personal data and a questionnaire battery. In this battery, more than just the self-efficacy questionnaire was administered because this research is part of a bigger project entitled "Developing a tool for evaluating aspects of the job of academics based on their triple profile (teacher, researcher and manager) and its influence on health", funded by Bancaja and Universidad Miguel Hernandez. Both the personal data document and the questionnaire battery ensured confidentiality because we did not ask for any identifying information. All documents were in Spanish.

### Data analyses

To begin with, we carried out a qualitative analysis in order to develop the scale. And, based on the *SCT* in general and on the Guide to Constructing Self-Efficacy Scales (Bandura, 2006) in particular, the first step on the way to constructing a reliable self-efficacy scale was to perform a conceptual analysis of the domain under study. We decided on two methods as the best way to study the work carried out by university faculty. Firstly, since the work of university faculty is regulated by law under the so-called LOU (Organic Law on Universities, 2001) and some of the tasks they carry out are stated in the law itself, we decided to start by studying it. Secondly, we held a discussion group so that faculty could make suggestions about our list of tasks and could contribute with tasks that had not been contemplated by the law.

Therefore, our first job was to conduct an exhaustive study of the main law that regulates Spanish Universities (the LOU), which is divided up into chapters, or titles as they are called. Once we had studied this law, members of the research project (specifically three members) used their work experience to express their opinion and to contribute, through a discussion group which lasted two hours, with

tasks that do not appear explicitly in legal texts, although they were considered fundamental.

In relation to teaching tasks, we focused mainly on title VI of the LOU. As a result, we decided that there were four main teaching tasks for university teachers: (1) determining elements and contents of academic training, (2) transmitting knowledge, abilities and competence, (3) communication with students, and (4) assessing students' learning. With regard to research tasks, we focused mainly on title VII of the LOU. Consequently, we decided that research involved six main tasks for university teachers: (1) updating the main research results, (2) updating the use of research methodologies from one's own speciality, (3) undertaking research of high scientific quality, (4) collaborating with teams inside and outside the university, (5) training new researchers, and (6) preparing monographs, reports, articles, communications and research projects to make the results of the research known.

As for management tasks, although title V of the LOU mentions the triple work profile in university teachers, not only is there no specific title for management, but in fact there are not even any documents explaining what is understood by management. Despite this situation, university faculty present at the discussion group considered the importance of management for university teachers. We identified three tasks. One is for management related to teaching: (1) tasks inherent to the academic management of the subject or subjects. Another is for management related to research: (2) tasks inherent to the management of research projects; and (3) tasks that are inherent to the administrative management of the present situation. In short, we identified thirteen tasks that could shape thirteen items.

Additionally *SCT* recommends that if there are no obstacles to overcome, the activity is undertaken easily and employees will have very high levels of self-efficacy in that activity. Specifically, Bandura (2006) stated that constructing scales to assess self-efficacy requires preliminary work to identify the forms both the challenges and impediments take. Consequently, our second step consists in presenting an obstacle for each task. We therefore formed a discussion group with five experts to summarise these challenges or obstacles. All members were university faculty of the university under study. In this discussion group, which lasted four hours, university faculty had to express the most common obstacles in all thirteen of the above-mentioned tasks. The discussion group was presented with the problem in the form of direct and open questions. A question was formulated for each scale item. Thus, in the case of Item 2 the question was the following: "At the time of transmitting knowledge, abilities and competence to students, which do you think are the main obstacles that could make this task difficult?" University faculty had to discuss the possible answers to this question and reach an agreement on the most common obstacle or impediment. Moreover, they had to assess how difficult it was to overcome each obstacle. This procedure was also followed to construct all the items.

In the third step, we considered the choice of answer scale. We followed the recommendations of Bandura (2006) and used a 10-point scale that ranged from 0 (“not at all”) to 9 (“absolutely”). In addition, each number was assigned a name to help make it easier to identify the most suitable number (see answer scale in Appendix).

Finally, we formulated the items as they appear in the scale. Thus, the item begins with “I can”, followed by the behavioural factor, and finally the proposed obstacle. So, a 13-item scale was constructed to measure self-efficacy in university faculty (see Appendix). The original scale was produced in Spanish but it was translated into English through back-translation by a professional translator.

Following with the data analyses section, confirmatory factor analyses (CFA), as implemented by AMOS (Arbuckle, 1997), were used to confirm the first secondary objective. We compared a one-factor model with a three-factor model corresponding to the triple work profile of university faculty and the goodness-of-fit of the models was evaluated using absolute and relative indexes. The four absolute goodness-of-fit indexes that were calculated were: (1) the  $\chi^2$  goodness-of-fit statistic; (2) the Goodness-of-Fit Index (GFI); (3) the Adjusted Goodness-of-Fit Index (AGFI); and (4) the Root Mean Square Error of Approximation (RMSEA). Additionally, we computed three relative indexes: (1) the Tucker-Lewis Index (TLI); (2) the Comparative Fit Index (CFI); and (3) the Incremental Fit Index (IFI). Because the distributions of the GFI and the AGFI are unknown, no statistical test or critical value is available (Jöreskog & Sörbom, 1986). Values

smaller than .06 for the RMSEA are indicative of an acceptable fit (Hu & Bentler, 1999), whereas a cut-off value close to .90 suggests a good fit for the IFI (Hoyle, 1995). As a rule of thumb for the remaining fit indexes (TLI, CFI), values greater than .95 are considered to indicate an adequate model fit (Hu & Bentler, 1999). Moreover, we carried out internal consistency (Cronbach’s alpha) and descriptive analyses to study the psychometric characteristics of the scale. Thirdly, in order to study the second objective, we carried out ANOVA analyses for work experience, level of academic education and marital status, and independent two-sample Student’s T tests for gender, occupational category and having children. The aim of these tests was to see whether all these variables could make any difference in self-efficacy among university faculty.

## Results

### Model testing

Once we had created the scale, our first secondary objective was to use CFA to demonstrate that the scale did actually have three factors that relate to the triple work profile. To do so, we used two alternative models: a one-factor model ( $M_1$ ) which assumed one latent factor, self-efficacy; and a three-factor model ( $M_2$ ) which assumed three latent and correlated factors, i.e. teaching self-efficacy, research self-efficacy and management self-efficacy.

**Table 1:** Confirmatory Factor Analyses (N = 166)

	$\chi^2$	df	$\chi^2/df$	GFI	AGFI	RMSEA	TLI	CFI	IFI	$\Delta\chi^2$	$\Delta df$
M1	663.54	65	10.20	.57	.41	.236	.57	.64	.64		
M2	200.86	62	3.23	.84	.76	.116	.90	.92	.92	M1-M2 = 462.68***	3
M2 <sub>a</sub>	149.46	60	2.49	.88	.82	.095	.93	.95	.95	M2-M2 <sub>a</sub> = 51.4***	2
M2 <sub>b</sub>	105.44	58	1.81	.91	.86	.070	.96	.97	.97	M2 <sub>a</sub> -M2 <sub>b</sub> = 44.02***	2

Note.  $\chi^2$  = Chi-square; df = degrees of freedom;  $\chi^2/df$  = ratio Chi-square/ degrees of freedom; GFI = Goodness-of-Fit Index; AGFI = Adjusted Goodness-of-Fit Index; RMSEA = Root Mean Square Error of Approximation; TLI = Tucker-Lewis Index; CFI = Comparative Fit Index; IFI = Incremental Fit Index. All the  $\chi^2$  differences between the models were statistically significant at \*\*\*p < .001. M1 = One-factor model; M2 = Three-factor model; M2<sub>a</sub> = Revised three-factor model, M2<sub>b</sub> = Revised three-factor model.

As seen in Table 1,  $M_2$  (three factors) fits better than  $M_1$  (one latent factor). Nonetheless,  $M_2$  does not offer a good fit, and this led us to review the modification index. The AMOS output proposes a covariance between two pairs of errors; 5 and 6, 9 and 10. Both covariances are performed within the same factor, i.e. research self-efficacy. Although both errors are in the same factor, it is recommendable to analyse them while searching for reasons for this relationship.

Items 5 and 6 focus on updating research as well as on the results obtained and the appearance of new methodologies. Thus, it seems that this covariance makes sense both statistically and theoretically. In the case of Items 9 and 10, what the two items have in common is that they do not concern the research itself, but deal instead with research outputs. Thus, one refers to how to train a new researcher in the

researching task, while the other refers to how to “sell” the result of the researching task. It seems that this covariance also makes sense.

Once we had completed both covariances ( $M_{2a}$ ), the index improved substantially, as can be seen in Table 1. Once again, however, the model does not fit satisfactorily and the modification index shows something peculiar, as it requests a relationship between Item 11 and the teaching factor, and Item 12 and the research factor. Item 11 would correspond to teaching management. In this sense, the fact that this item comprises two factors (teaching and management) makes sense. Item 12 would correspond to research management. And again, in this sense, the fact that this item comprises two factors (research and management) also makes sense.

Once again, in Table 1 we can see how the index improves the fit ( $M_{2b}$ ).

Finally, the definitive CFA is shown in Figure 1.

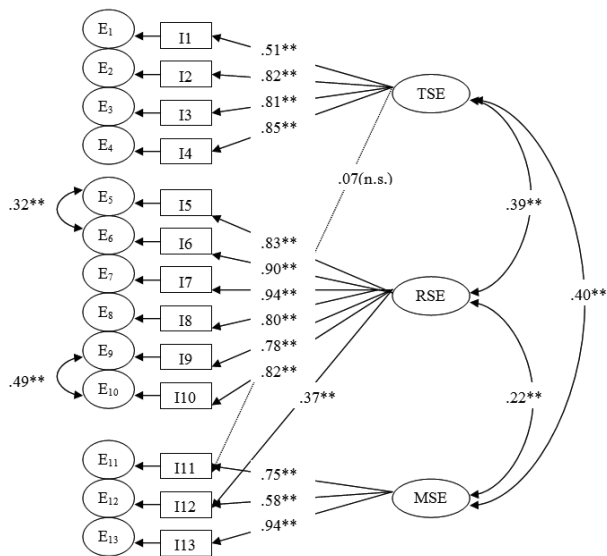

Figure 1: Confirmatory factor analyses

Note. \*\* $p < .001$ ; I1 = Item 1, I2 = Item 2, (...), I13 = Item 13; TSE = Teaching Self-efficacy, RSE = Research Self-efficacy, MSE = Management Self-efficacy; E = error.

### Descriptive Analyses

Table 2 shows the means, standard deviations and inter-correlations of the 13 items of the scale and its three dimensions. As Table 2 illustrates, although not all correlations are significant, their items all positively and significantly correlate within each dimension. Moreover, there is no negative correlation. In the same table, we can see the internal consistency scores (Cronbach's alpha) for all the dimensions which met the criterion of .80 (Henson, 2001), TSE (5 items)  $\alpha = .80$ , RSE (7 items)  $\alpha = .91$  and MSE (3 items)  $\alpha = .82$ .

Finally, we carried out ANOVA analyses and independent two-sample Student's T tests to determine whether differences in self-efficacy in university faculty exist according to some sociodemographic variables such as gender, work experience, occupational category, levels of academic education, marital status and having children (that is, the second objective) and found no significant differences in teaching self-efficacy for any of the variables. The level of academic education produced significant differences ( $F = 4.99, p < .05, \eta^2 = .045$ ) in research self-efficacy. Accordingly, as the level of academic education increases, self-efficacy also increases. Therefore, the highest scores in research self-efficacy were found in university faculty members who had a doctoral degree, while the lowest score was seen among the university faculty who had completed a diploma course. We found no significant differences in management self-efficacy for any of the variables.

Table 2: Means (M), Standard Deviation (SD), Internal Consistencies (Cronbach's alpha), and intercorrelations (N = 166)

	M	SD	I1	I2	I3	I4	I5	I6	I7	I8	I9	I10	I11	I12	I13	TSE	RSE	MSE
I1	6.93	1.55	1															
I2	6.99	1.33	.423**	1														
I3	7.02	1.45	.418**	.663**	1													
I4	6.67	1.65	.411**	.703**	.687**	1												
I5	5.75	1.86	.187*	.154*	.288**	.261**	1											
I6	5.60	1.96	.133	.260**	.271**	.347**	.822**	1										
I7	5.45	2.17	.126	.291**	.271**	.315**	.777**	.855**	1									
I8	5.73	2.18	.136	.154*	.289**	.241**	.696**	.698**	.757**	1								
I9	5.11	2.32	.187*	.329**	.248**	.318**	.621**	.716**	.726**	.652**	1							
I10	5.82	2.15	.252**	.363**	.295**	.346**	.671**	.715**	.769**	.701**	.816**	1						
I11	6.46	1.46	.302**	.253**	.364**	.284**	.147	.135	.136	.150	.209**	.219**	1					
I12	5.79	1.68	.264**	.304**	.276**	.354**	.412**	.452**	.458**	.338**	.494**	.444**	.457**	1				
I13	5.98	1.62	.305**	.288**	.295**	.306**	.127	.170*	.165*	.181*	.315**	.228**	.743**	.633**	1			
TSE	6.90	1.22	.699**	.844**	.846**	.868**	.276**	.312**	.307**	.254**	.331**	.385**	.370**	.370**	.368**	0.80		
RSE	5.58	1.86	.194*	.297**	.314**	.346**	.858**	.903**	.923**	.853**	.864**	.888**	.190*	.492**	.240**	.354**	0.91	
MSE	6.08	1.37	.337**	.328**	.360**	.368**	.272**	.300**	.302**	.263**	.402**	.374**	.838**	.823**	.920**	.429**	.364**	0.82

Note. \*  $p < .05$ , \*\*  $p < .001$ ; I1 = Item 1, I2 = Item 2, (...), I13 = Item 13; TSE = Teaching Self-efficacy. RSE = Research Self-efficacy, MSE = Management Self-efficacy. Cronbach's alpha values of the dimensions are on the diagonal.

### Discussion

The main objective of this research was to show the work method carried out to develop a new scale to measure specific self-efficacy (in this case, in university faculty) and which takes their triple work profile into account. The objective of this work therefore was not to create the scale itself, but to describe the work method carried out to obtain that scale. Moreover, the aim of this work was not to generalise the scale that was created because, in line with SCT, we have argued that measures in self-efficacy cannot be generalised, but are instead specific to the sample to be measured. Thus,

the ultimate goal was to show a work method that can be followed to measure specific self-efficacy in any domain.

Although the literature does contain studies that show us how to create a self-efficacy scale (i.e. Bandura, 2006) and this process is similar for many kinds of self-efficacy scales, what we have proposed with this study is how to do it. For instance, Bandura (2006) explained that the first step to construct a reliable self-efficacy scale is a conceptual analysis of the domain under study. We have therefore shown how we achieved this: 1) by conducting a study of the LOU law, and 2) through a discussion group. Perhaps for another domain other techniques are required.

In this line, Prieto (2008) reported a great research study about self-efficacy among university faculty, and even showed a scale for measuring it that she herself had created, as there is no specific scale for university faculty. But, as we have already said, this scale only focuses on the teaching task, forgetting two important roles: research and management. Moreover, there is no detailed information in her book about the process by which the scale was created. And this is the void that this study has tried to fill.

We have shown how the qualitative analysis is carried out to obtain the items of the scale. Furthermore, the hypothesis that the scale is made up of three latent factors corresponding to the triple work profile of university faculty is confirmed. We carried out CFA and the results largely met the criterion: all indexes fully surpassed the values marked as the criterion, except the RMSEA, which was not lower than 0.06 but came very close to this value (0.07). In addition, model  $M_2$  (three latent factors) fitted better than model  $M_1$  (one latent factor). So we can state that this scale consists of three latent, correlated factors: teaching, research and management. Moreover, results showed that the items of each dimension correlated positively and significantly and that correlations were high. Moreover, the Cronbach's alphas confirmed that the participants' scores on the scale should be considered reliable. Thus, all dimensions met the criterion of 0.80 (Henson, 2001).

Furthermore, it was confirmed that the chosen sociodemographic variables included in this study (gender, work experience, occupational category, levels of academic education, marital status and having children) make no difference to self-efficacy in both teaching and management self-efficacy among university faculty. In research self-efficacy, however, we saw that one variable presented marked differences, i.e. the level of academic education. As the level of academic education increases, self-efficacy also increases. This result is to be expected because both research aptitude and doctoral studies have similar purposes, that is to say, to learn how to do research (among other things). Hence, university faculty members with a specific education in research

show the highest scores in research self-efficacy. In addition, these results agreed with those from other studies (Hoy & Woolfolk, 1993).

We firmly believe that this study can serve as an example of how to construct a self-efficacy scale within the *SCT*, because with this study we have shown how to put Bandura's guidelines into practice. Furthermore, we can learn about the situation in which university faculty find themselves through the theoretical contributions that this study offers. Past research had already denounced the few studies conducted in university faculty by considering their differences in relation to those of primary and secondary schools (Burton et al., 2005; Gozalo & León, 1999; Prieto, 2005).

However, this research has its limitations. Firstly, the sample size: only a low percentage (17.4%) of university faculty completed the scale. Moreover, we used a convenient sample and then all university faculty members were included so that all such university faculty had the chance to respond on the scale. This method is possibly not the most effective in sample collection and we could have used another type of sampling. Secondly, the ANOVA and the Student's T test showed that the level of academic education produced significant differences in research self-efficacy, but the effect size measure ( $\eta^2 = .045$ ) is low. This may be due to the relatively large sample size for the ANOVA. Even so, these differences exist and are very logical.

As far as the validity of the scale is concerned, our scale fulfilled content validity once we had completed an exhaustive study on self-efficacy in a specific context, i.e. the university. It was not possible to verify criterion validity since other scales which measure self-efficacy in our population, and which consider their triple work profile, do not exist.

This work method could also be used in other universities in future research, where different self-efficacy scales could be created for each university. It would be interesting to see how this work method functions in other universities.

**Note.-** This research was supported by grants from Universidad Miguel Hernández & Bancaixa.

## References

- Arbuckle, J. L. (1997). *Amos Users' Guide version 4.0*. Chicago, IL: Smallwaters Corporation.
- Anderson, R., Greene, M., & Loewen, P. (1988). Relationships among teachers' and students thinking skills, sense of efficacy and student achievement. *Alberta Journal of Educational Research*, *34*, 148-165.
- Armor, D., Conroy-Oseguera, P., Cox, M., King, N., McDonnell, L., Pascal, A., Pauly, E., & Zellman, G. (1976). *Analysis of the school preferred reading programs in selected Los Angeles minority schools*. REPORT NO. R-2007-LAUSD. Santa Monica, CA: Rand (Eric Document reproduction service no: ED 130 243).
- Bandura, A. (1997). *Self-efficacy. The exercise of control*. New York: Freeman.
- Bandura, A. (2006). Guide for constructing self-efficacy scales, in F. Pajares and T. Urdan (Eds.), *Self-efficacy beliefs of adolescents* (Vol. 5, pp. 307-337). Information Age. Greenwich.
- Benz, C., Bradley, L., Alderman, L., & Flowers, M. (1992). Personal teaching efficacy: developmental relationships in education. *Journal of Educational Research*, *85*, 274-286.
- Brouwers, A., & Tomic, W. (2001). The factorial validity of scores on the teacher interpersonal self-efficacy scale. *Educational and Psychological Measurement*, *61*, 433-445.
- Brouwers, A., Evers, W., & Tomic, W. (2001). Self-efficacy in eliciting social support and burnout among secondary-school teachers. *Journal of Applied Social Psychology*, *31*, 1474-1491.
- Buela-Casal, G. & Sierra, J. C. (2007). Criterios, indicadores y estándares para la acreditación de profesores titulares y catedráticos de Universidad [Criteria, indicators and standards for the accreditation of lectures and university professors]. *Psicothema*, *19*(4), 537-551.
- Burton, J. P., Bamberry, N., & Harris-Boundy, J. (2005). Developing personal teaching efficacy in new teachers in university settings. *Academy of Management Learning & Education*, *4*, 160-173.
- Chacón, S., Pérez-Gil, J. A., Holgado, F. P., & Lara, A. (2001). Evaluación de la calidad universitaria: validez de contenido [University quality assessment: content validity]. *Psicothema*, *13*(2), 294-301.

- Cifre, E., Llorens, S., & Salanova, M. (2003). Riesgos psicosociales en Profesores Universitarios. ¿Existen diferencias atendiendo a su categoría profesional? [Psychosocial risks among University Faculty: Do differences into professional category exists?]. *Psicología Social Aplicada*, 13, 29-54.
- Coladarci, T., & Breton, W. (1997). Teacher efficacy, supervision, and the special education resource-room teacher. *Journal of Educational Research*, 90, 230-239.
- Currie, J. (1996). The effects of globalisation on 1990s: Overworked, stressed out and demoralised. *Melbourne Studies in Education*, 37, 101-128.
- Gozalo, M., & León, B. (1999). La promoción de la autoeficacia en el docente universitario. [The promotion of self-efficacy in university teaching staff]. *Revista Electrónica Interuniversitaria de Formación del Profesorado*, 2, 79-90. Retrieved January 13, 2006, from <http://www.uva.es/aufoop/publica/revelfop/99-v2n1.html>.
- Henson, R. K. (2001). Understanding internal consistency reliability estimates: A conceptual primer on coefficient alpha. *Measurement and Evaluation in Counseling and Development*, 34, 177-189.
- Hoy, W. K., & Woolfolk, A. (1990). Socialization of student teachers. *American Educational Research Journal*, 27, 279-300.
- Hoy, W. K., & Woolfolk, A. E. (1993). Teacher's sense of efficacy and the organizational health of schools. *The Elementary School Journal*, 93, 356-372.
- Hoyle, R. H. (1995). The structural equation modeling approach: Basic concepts and fundamental issues. In R.H. Hoyle (Ed.), *Structural equation modeling: Concepts, issues and applications* (pp. 1-15). Thousand Oaks, CA: Sage.
- Hu, L., & Bentler, P. M. (1999). Cut off criteria for fit indexes in covariance structure analysis: Conventional criteria versus new alternatives. *Structural Equation Modeling*, 6, 1-55.
- Jöreskog, K. G., & Sörbom, D. (1986). *LISREL user guide version VI (4th ed.)*. Mooresville, IL: Scientific Software International.
- Klassen, R. M., Bong, M., Usher, E. L., Chong, W. H., Huan, V. S., Wong, I. Y. F., & Georgiou, T. (2009). Exploring the validity of a teachers' self-efficacy scale in five countries. *Contemporary Educational Psychology*, 34, 67-76.
- Klassen, R. M., & Chiu, M. M. (2010). Effects on teachers' self-efficacy and job satisfaction: Teacher gender, years of experience, and job stress. *Journal of Educational Psychology*, 102, 741-756.
- Ley Orgánica de Universidades (LOU) [Organic Law on Universities], 21st December, BOE 307 [Congressional record] 24th December, 2001). Law 6/2001, Sec. 49400-49425. Retrieved November 12, 2005, from <http://www.boe.es/boe/dias/2001/12/24/pdfs/A49400-49425.pdf>
- Morrison, A. A. (1996). University staff research time - what gets in the way? Different Approaches: Theory and Practice in Higher Education. *HERDSA Annual International Conference*, Perth, Western Australia, 8-12 July. Retrieved February 5, 2006, from <http://www.herdsa.org.au/confs/1996/morrison.html>.
- Prieto, L. (2002). El análisis de las creencias de autoeficacia: Un avance hacia el desarrollo profesional del docente. [Self-efficacy analysis: towards the professional development of the teacher]. *Miscelánea Comillas*, 60, 591-612.
- Prieto, L. (2005). Las creencias de autoeficacia docente del profesorado universitario [Efficacy beliefs among University Faculty]. Universidad Pontificia Comillas de Madrid: Tesis doctoral no publicada. Retrieved March 29, 2011, from <http://www.des.emory.edu/mfp/PrietoInstrument.pdf>
- Prieto, L. (2008). *Autoeficacia del profesor universitario. Eficacia percibida y práctica docente*. Madrid: Narcea.
- Raudenbush, S., Rowen, B., & Cheong, Y. (1992). Contextual effects on the self-efficacy of high school teachers. *Sociology of Education*, 65, 150-167.
- Rotter, J. B. (1966). Generalized expectancies for internal versus external control of reinforcement. *Psychological Monographs*, 80, 1-28.
- Schwarzer, R., Schmitz, G. S., & Daytner, G. T. (1999). *The Teacher Self-Efficacy scale*. [On-line publication]. Retrieved February 6, 2006, from <http://www.fu-berlin.de/gesund/shaken/language-Selection/turkish/teacher-self-efficacy/teacher-self-efficacy.html>.
- Tschannen-Moran, M., Woolfolk Hoy, A., & Hoy, W. K. (1998). Teacher efficacy: Its meaning and measure. *Review of Educational Research*, 68, 202-248.
- Tschannen-Moran, M., & Woolfolk, A. (2001). Teacher efficacy: capturing an elusive construct. *Teaching and Teachers Education*, 17, 783-805.
- Vera, M., Salanova, M., & Martín del Río, B. (2010). University faculty and work-related well-being: the importance of the triple work profile. *Electronic Journal of Research in Educational Psychology*, 8, 581-602.
- Wolters, C. A., & Daugherty, S. G. (2007). Goal structures and teachers' sense of efficacy: Their relation and association to teaching experience and academic level. *Journal of Educational Psychology*, 99, 181-193.

(Artículo recibido: 27-4-2009; revisión: 31-3-2011; aceptado: 05-4-2011)

## Appendix

### With regard to the TEACHING I undertake at University, I can:

1. Determine contents of academic training even when I must decide from among a considerable number those which are fundamental and those that are additional.
2. Transmit knowledge even when material means are not sufficiently appropriate.
3. Communicate with students even when the characteristics of the group of students are not favourable.
4. Assess the students' learning even when it is difficult to appreciate all its aspects (e.g. competences).

### With regard to the scientific RESEARCH I undertake at University, I can:

5. Update the main research results even when there are a considerable number.
6. Update the use of research methodologies from my own speciality even when it is difficult to me to gain access to them.
7. Research with high scientific quality.
8. Collaborate with teams inside and outside the university even when access to other research groups is difficult.
9. Train new researchers even when the economic means are insufficient.
10. Prepare research projects to diffuse the research results even when I am not a member of top research groups.

### With regard to the MANAGEMENT I undertake at University, I can:

11. Carry out tasks inherent to the academic management of my subject or subjects even when the system is excessively bureaucratic.
12. Carry out tasks inherent to the management of research projects which I participate in even when the regulating conditions change.
13. Carry out tasks inherent to the administrative management of the present situation even when I depend on the work of others to complete them.

### Answer scale:

0	Not at all
1	Hardly
2	Very slightly
3	Slightly
4	Somewhat
5	Sufficiently
6	Fairly
7	Considerably
8	Most considerably
9	Absolutely